

CASE STUDY



SHERRINGTON LIFTING SERVICES

CASE STUDY

CHALLENGE



Our client is fitting the internal heating and ventilation units to a new build large industrial warehouse.

The total footprint of the building is 62,000m² yet only had a maximum eaves height of 18m with sprinkler systems in the roof limiting useable height.

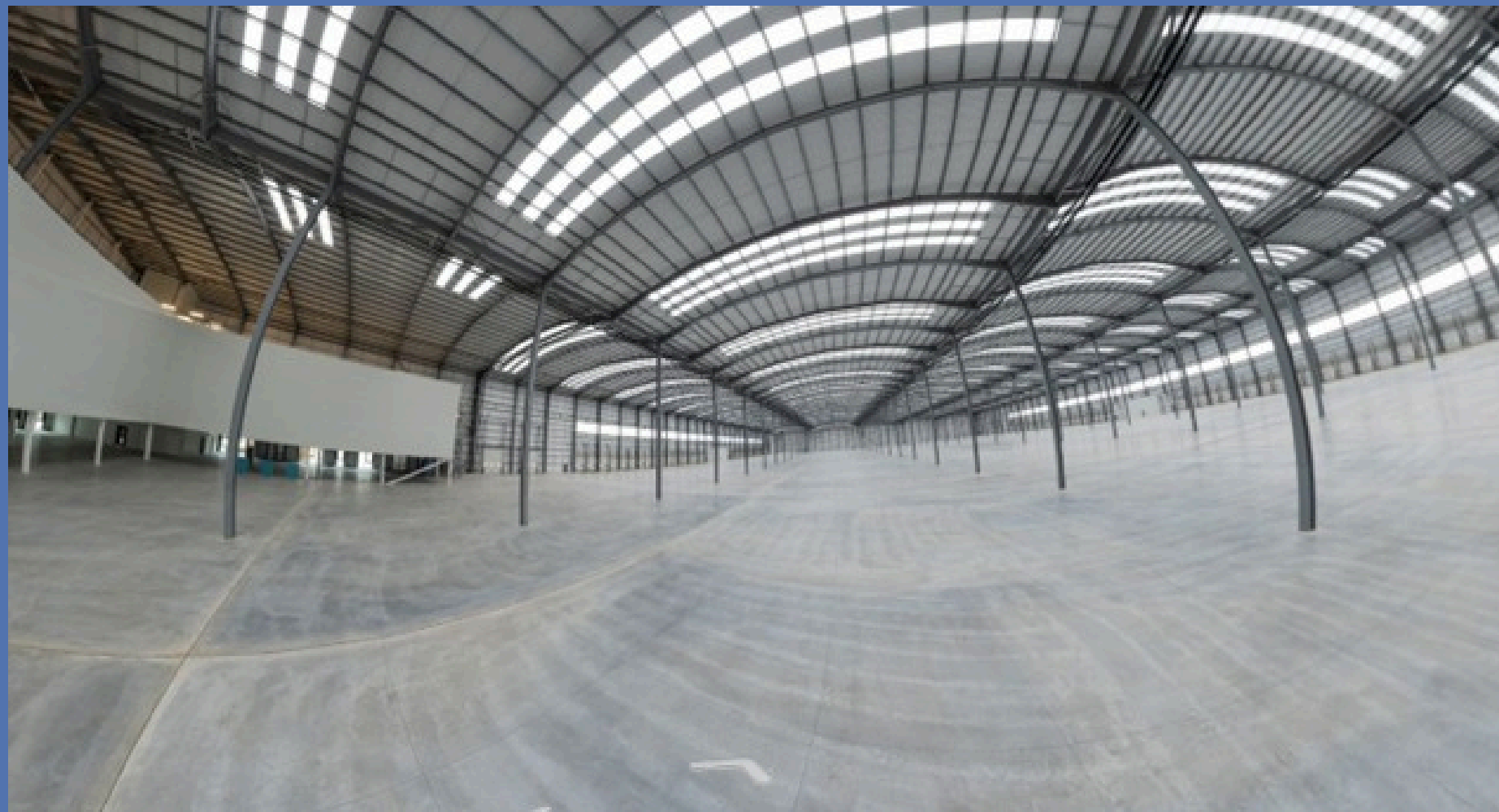

CASE STUDY

WHAT WE PLANNED

We supplied a full lifting package with all required lifting equipment including telehandler with operator for offloading and moving loads around the warehouse.

We were provided concrete slab design to work with and ensured our outrigger loadings worked with the requirements.

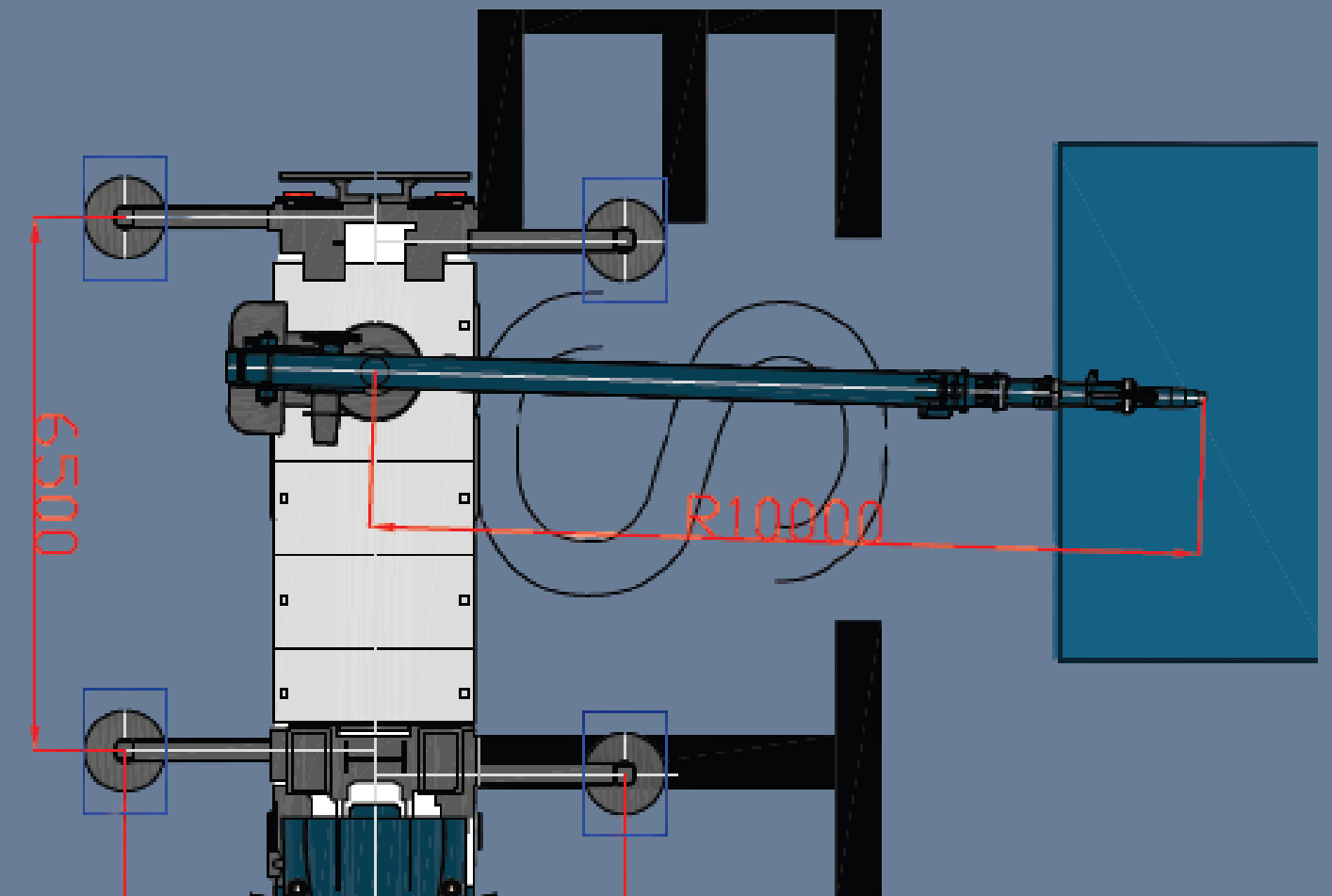
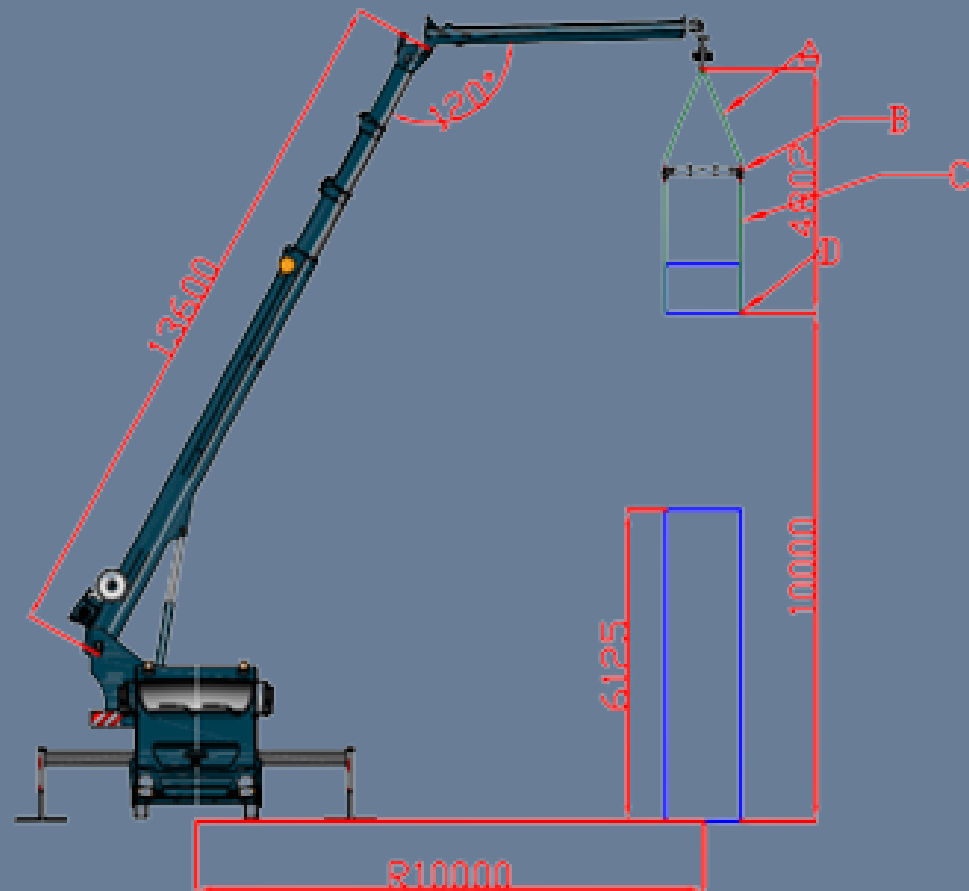

CASE STUDY

WHAT WE DID

Over a week long project we supplied Bocker AK46 on full contract lift with telehandler, telehandler operator, additional mats and required lifting equipment. We utilised our in house multi mat system to reduce outrigger loadings and protect the new concrete slab. All works where completed safely and within initial timescales.



CASE STUDY

WHAT THEY SAID



Customer Comments Below

“The lift went better than we had hoped.
Really pleased with the service you guys provided.”

ABOUT US



Trusted Experts in Safe & Reliable Lifting Solutions

Experienced Crane Hire & Lifting Specialists in Liverpool, Manchester & the North West
At Sherrington Lifting Services, we are committed to delivering safe, efficient, and reliable lifting solutions across Liverpool, Manchester, and the North West.

Whether you need mobile cranes, contract lifts, or specialist lifting support, our expert team ensures every project is completed with precision and care.

With an extensive fleet of modern cranes, a highly skilled workforce, and a dedication to safety, we help businesses across construction, infrastructure, and industrial sectors achieve their lifting goals with confidence.

W: sherringtonlifting.co.uk

E: info@sherringtonlifting.co.uk

T: 0151 440 2204